

PR60

Rolling High-speed Door

with Stainless Steel Frame.



Technical Description.

The **PR60 high-speed door** from **Inkema**, featuring a **high-quality stainless steel finish**, is the perfect choice for installations in the demanding food industry, where saline and corrosive environments are common.

All screw and fitting components have a complete finish in either 304 or 316 stainless steel. Its curtain is of high quality, weighing 900g/m², with composite reinforcements to prevent oxidation and, at the same time, deformable to facilitate manual insertion in case of an impact on the curtain.

Additionally, the **PR60** incorporates polyethylene sliding pieces in the guides for smooth operation and to prevent residue caused by friction.

Technical Features.

- **Application:** Indoor
- **Max. Size:** 3400 × 3400 mm (width x height)
- **Material (structure):** Stainless Steel 304 (316 optional)
- **Max. Speed:** Opening: (~1,0m/s)
Closing: (~1,0m/s)
- **Canvas Colours:** 10 colors (white, cream, yellow, orange, red, light blue, dark blue, green, grey, and black).
- **Canvas Material:** High-Resistance PVC (900g/m²)
- **Safety:** Emitter/Receiver or Photoelectric Curtain
- **Wind Resistance:** Class 1 (EN12424)
- **Life Cycle:** 750,000 cycles

Additional Features.

Features	● ○
Light curtain	○
Frequency inverter	○
Uninterruptible Power Supply (UPS)	○
Stainless Steel Frame	○
Motor cover	●
Frontal Motor	○
A row of small windows	●
Additional push button panel	○
Intermediate Stop	●
Stainless Steel	●
Aquaproof	○

● Standard Feature ○ Optional Feature *For other options, consult Customer Service.

The Inkema **PR60 High-speed Door** has been designed and manufactured in accordance with European standard: **EN 13241-1**

Standard Model Operation:

- Electronic End-of-Travel Sensor (Encoder).
- Power Supply Voltage: 230/400V III + N. Optional 230V I.
- Voltage Isolator at the main switch.
- Emergency Stop (optional).
- Manual Emergency/Maintenance Opening.
- Uninterruptible power supply UPS (optional).



Aquaproof Model Operation (optional).

- Motor IP65 GFA Elektromaten
- IP65 Panel with GFA Elektromaten Membrane
- Clutch-Release Motor for Manual Operation



Safety Systems.

The **PR60** high-speed door comes standard with a safety system based on the installation's characteristics:

Either a **Safety Light Curtain** or a **Safety Photocell**.



Safety Photocell.



Light Curtain.

Dimensions.

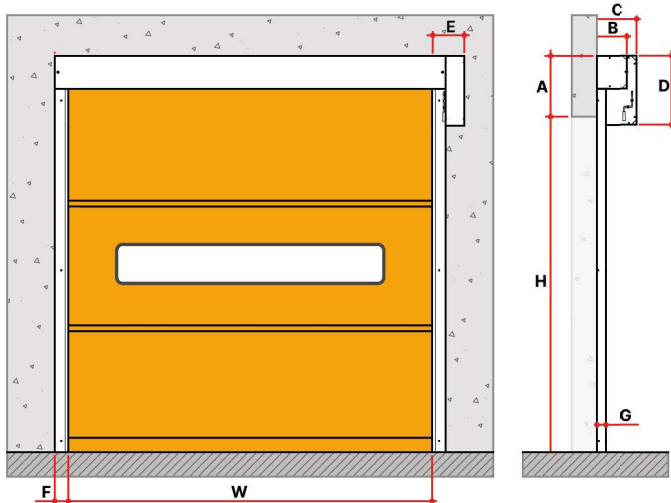

H	W	A	B	C	D	E	F	G
3400(2000)	3400(820)	470	246	317	505	276	120	102

Canvas Color Range.



(White, Cream, Yellow, Orange, Red, Light Blue, Blue, Green Grey, Black and 100% Personalised).